



**Technical Service
Information Bulletin**

February 14, 2008

Title:

**DRIVELINE VIBRATION/DRONE
BETWEEN 55 - 75 MPH**

Models:

'03 - '08 GX 470

**DRIVELINE & DIFFERENTIAL
DL001-08**

Introduction Customers of some 2003 – 2008 model year GX 470 vehicles may complain of a vibration/drone felt in the floorboard or seat when maintaining steady speeds between 55 and 75 mph. The following procedure has been developed to address this condition.

Applicable Vehicles

- **2003 – 2008** model year **GX 470** vehicles.

**Parts
Information**

NO. (SEE NOTE)	PREVIOUS PART NUMBER	CURRENT PART NUMBER	PART NAME	QTY
1	41196-60010	41196-60020	Differential Dynamic Damper	1
2	—	90105-A0051	Flange Bolt	2
3	36293-35040	36293-35060	Transfer FR Drive Chain	1
4	—	33183-60070	Dynamic Damper (for Transfer)	1
5	—	91619-61235	Bolt w/Washer	2
6	—	04362-60120	Gasket and Seal Kit	1

NOTE:

Parts 1 & 2 are applicable **ONLY** to vibration/drone at 55 – 65 mph.

Parts 3, 4, 5, & 6 are applicable **ONLY** to vibration/drone at 70 – 75 mph.

**Warranty
Information**

55 – 65 mph Vibration/Drone:

OP CODE	DESCRIPTION	TIME	OFF	T1	T2
DL7003	Install Revised Dynamic Differential Damper	0.5	41196-60010	9B	99

70 – 75 mph Vibration/Drone:

OP CODE	DESCRIPTION	TIME	OFF	T1	T2
DL7004	Install Transfer FR Drive Chain and Transfer Case Dynamic Damper	8.5	36293-35040	9B	99

Applicable Warranty*:









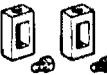

This repair is covered under the Lexus Powertrain Warranty. This warranty is in effect for 72 months or 70,000 miles, whichever occurs first, from the vehicle's in-service date.

* Warranty application is limited to correction of a problem based upon a customer's specific complaint.

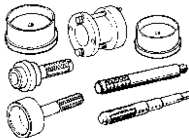

Required Tools & Equipment

TOOLS & MATERIAL	QUANTITY
Gear Oil, API GL-5, SAE 75W90	1.4 liters
FIPG Sealant: P/N 08826-00090, Three Bond 1281, or Equivalent	As Needed
Sealant: P/N 08833-00080, Toyota Genuine Adhesive 1344, Three Bond 1344, Loctite 242, or Equivalent	As Needed
MP Grease	As Needed

SPECIAL SERVICE TOOLS (SSTs)	PART NUMBER	QTY	DRW**
Companion Flange Holding Tool* 	09330-00021	1	3
Universal Puller Set "B"*** 	09950-40011-02	1	24
<div style="display: flex;"> <div style="writing-mode: vertical-rl; transform: rotate(180deg); font-weight: bold; margin-right: 10px;">COMPONENT(S) OF KIT/SET</div> <div> <p>Seven (7) components from this kit/set are required:</p> <ul style="list-style-type: none"> • Hanger 200 (P/N 09951-04020)  • Slide Arm (P/N 09952-04010)  • Center Bolt 200 (P/N 09953-04030)  • Arm 25 (P/N 09954-04010)  • Claw No. 5 (P/N 09955-04051)  • Attachment (P/N 09957-04010)  • Holder (P/N 09958-04011)  </div> </div>			
Crankshaft Service Tool Set* 	00002-62091-02	1	24
<div style="display: flex;"> <div style="writing-mode: vertical-rl; transform: rotate(180deg); font-weight: bold; margin-right: 10px;">COMPONENT(S) OF KIT/SET</div> <div> <p>One (1) component from this kit/set is required:</p> <ul style="list-style-type: none"> • Crankshaft Front Oil Seal Replacer (P/N 09223-46011)  </div> </div>			







* Essential SST.

** Drawer number in SST Storage System.

*** These tools may be ordered from SPX/OTC, or an equivalent tool may be used.

NOTE:
Additional SSTs may be ordered by calling SPX/OTC at 1-800-933-8335.

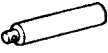
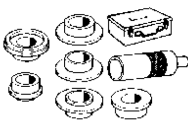
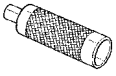
Required Tools & Equipment
(Continued)

SPECIAL SERVICE TOOLS (SSTs)		PART NUMBER	QTY	DRW**
	Seal Ring Tool* 	09631-32020	1	12
	Replacer Set #1* 	09950-60010-02	1	23
COMPONENT(S) OF KIT/SET	<p>Two (2) components from this kit/set are required:</p> <ul style="list-style-type: none"> • Replacer 32 (P/N 09951-00320-01)  • Replacer 59 (P/N 09951-00590-01)  			
	Handle Set* 	09950-70010-02	1	23
COMPONENT(S) OF KIT/SET	<p>One (1) component from this kit/set is required:</p> <ul style="list-style-type: none"> • Handle Assembly 100 – 4.25 inch (P/N 09951-07100-01)  			
	Transmission Transfer Bearing Replacer Set 	09316-60011	1	
COMPONENT(S) OF KIT/SET	<p>One (1) component from this kit/set is required:</p> <ul style="list-style-type: none"> • Replacer Pipe*** (P/N 09316-00011, or Equivalent)  			
	Pilot Bearing Installer*** 	09304-12012 (or Equivalent)	1	

* Essential SST.

** Drawer number in SST Storage System.

*** These tools may be ordered from SPX/OTC, or an equivalent tool may be used.

NOTE:

Additional SSTs may be ordered by calling SPX/OTC at 1-800-933-8335.

Diagnostic Procedure

Confirm customer complaint of vibration/drone felt in the floorboard or seat between 55 – 75 mph by test driving the vehicle and note the speed range in which the vibration/drone occurs.

- Does the vibration/drone occur in the 55–65 mph range?
If **YES** — Go to *Front Differential Damper Installation/Replacement* in this TSIB.
If **NO** — go to next question.
- Does the vibration/drone occur between 70–75 mph?
If **YES** — Go to *Transfer Case Drive Chain Replacement/Transfer Case Dynamic Damper Installation* in this TSIB.
If **NO** — This TSIB does NOT apply.

Repair Procedure **Front Differential Damper Installation/Replacement
(55 – 65 mph Vibration/Drone Only)**

1. Confirm if the vehicle has the original differential dynamic damper installed.

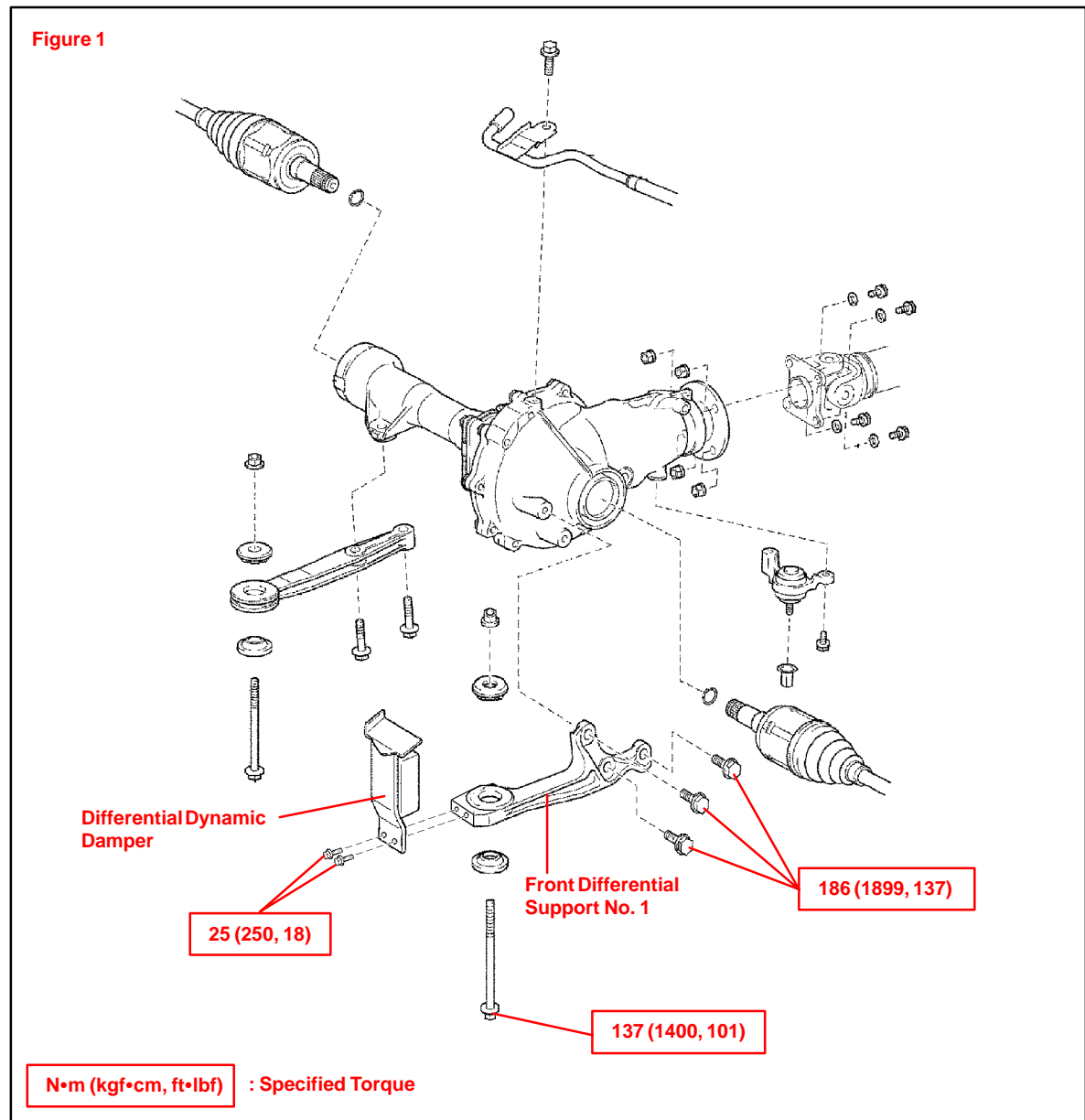

NOTE:

- 2003 – 2004 model year GX 470:
If the vehicle has had TSIB No. ST004–04 performed *OR* is produced *AFTER* VIN # JTJBT20X*40032263, the differential dynamic damper has been installed.
- 2005 – 2008 model year GX 470:
These vehicles are equipped with factory installed differential dynamic damper on the front differential.
- If the vehicle is produced *BEFORE* the Production Change Effective VIN listed in TSIB No. ST004–04, and TSIB No. ST004–04 has *NOT* been performed, then the front differential support No. 1 *MUST* be replaced with a revised part. Please refer to TSIB No. ST004–04 for proper part number.

- Repair Procedure**
(Continued)
2. Remove the engine under cover front (refer to Figure 2).
 3. Remove the engine under cover sub-assembly No. 1 (refer to Figure 2).

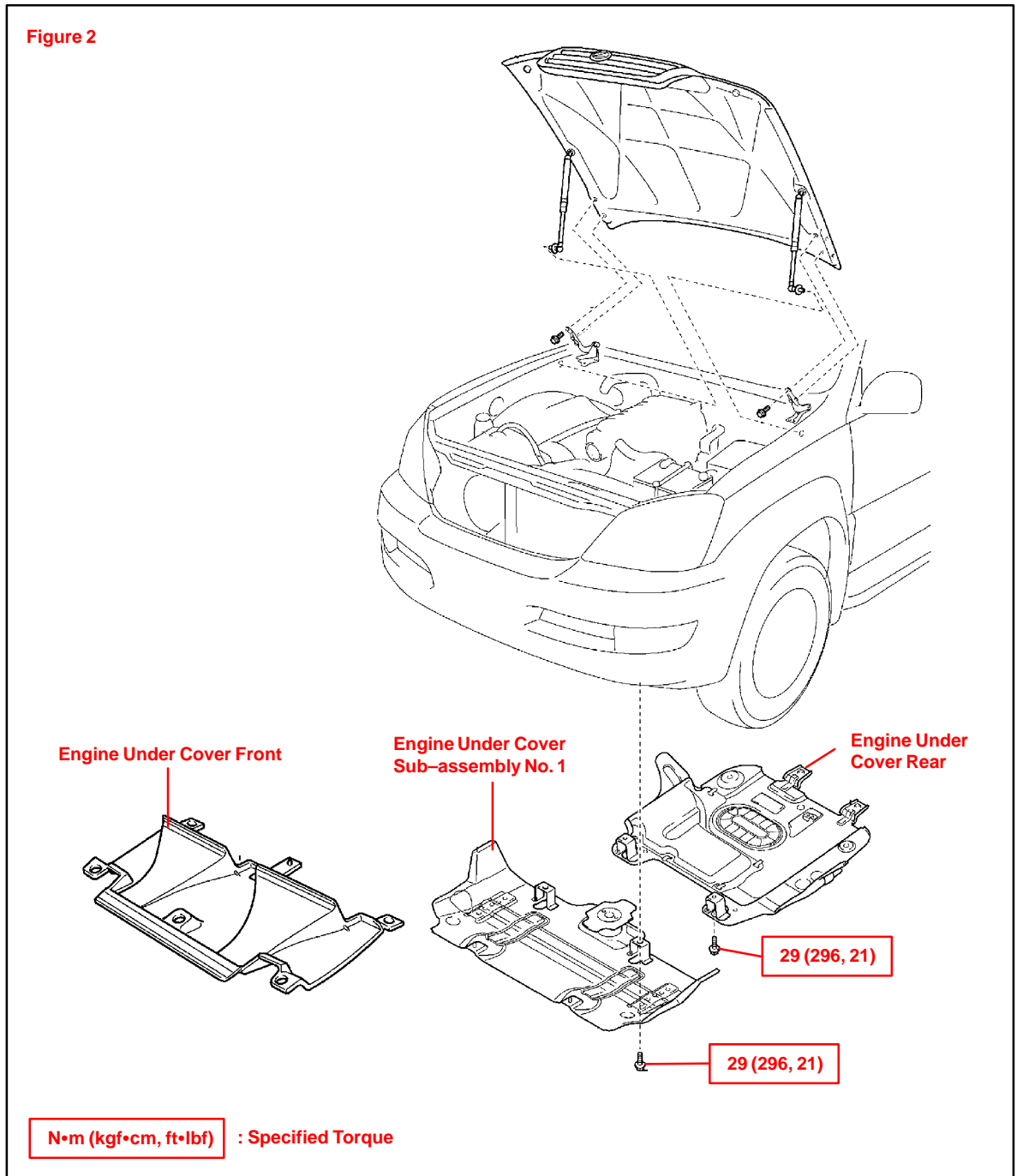

4. Remove the differential dynamic damper assembly from the front differential support No. 1.
5. Install the NEW differential dynamic damper assembly with 2 new bolts (see Figure 1).

Torque: 25 N•m (250 kgf•cm, 18 ft•lbs)

**Repair
Procedure**
(Continued)

6. Test drive the vehicle and confirm the vibration/drone heard between 55 – 65 mph is eliminated. Repair is complete.

**Transfer Case Drive Chain Replacement/Transfer Case Dynamic Damper
Installation (70 – 75 mph Vibration/Drone Only)**

1. Drain the transfer oil.
2. Remove the transfer case lower protector by removing the 4 bolts.

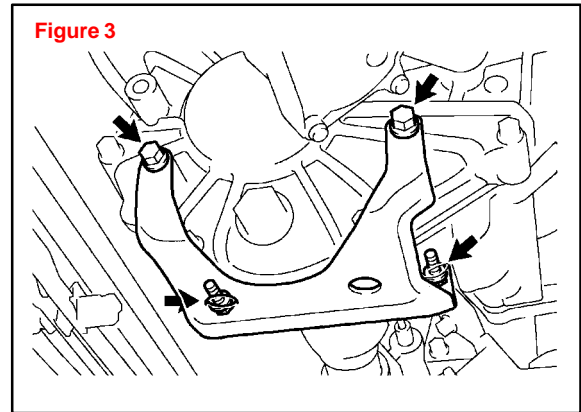

3. Remove the automatic transmission assembly.
Refer to the Technical Information System (TIS):
 - 2003, 2004, or 2005 model year GX 470 Repair Manual: *Drivetrain – Automatic Transmission/Transaxle – “Automatic Transmission Assy: Replacement”*
 - 2006 or 2007 model year GX 470 Repair Manual: *Drivetrain – Automatic Transmission/Transaxle – “A750F Automatic Transmission: Automatic Transmission Assembly: Removal”*

4. Remove the transfer assembly.
Remove the 8 bolts and 2 clamps from the transmission.

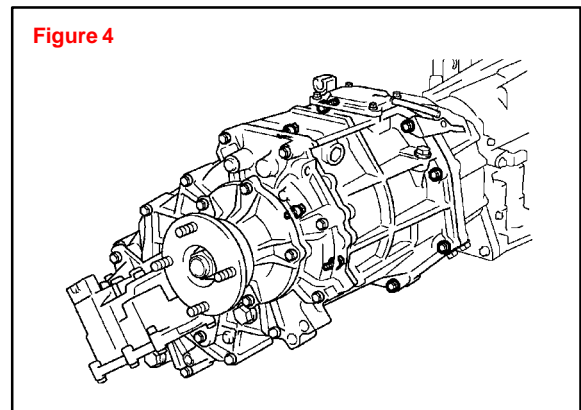

Repair Procedure
(Continued)

- Remove the actuator motor breather hoses.

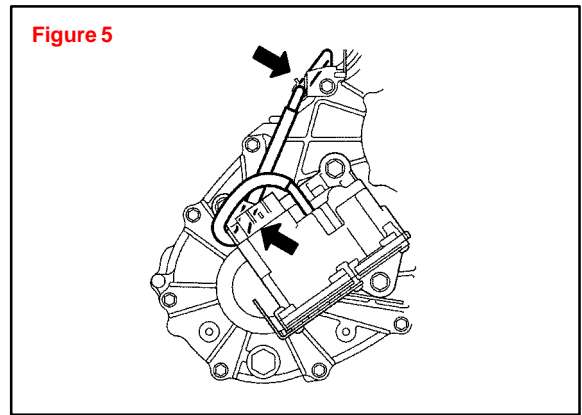

- Remove the switches.
Remove the indicator No. 1 and No. 2 switches, case No. 1 plug, and gaskets.

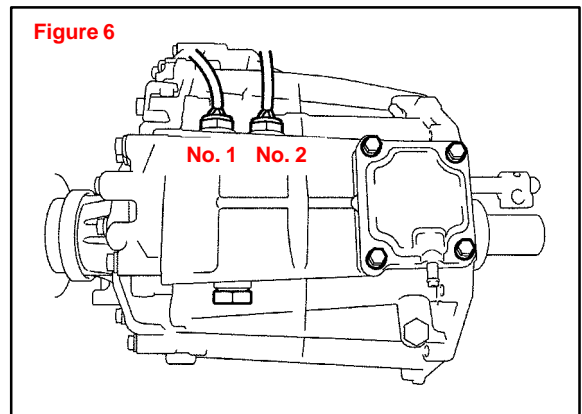

- Remove the transfer gear shift head No. 2.
Using a pin punch and hammer, remove the slotted pin from the gear shift head No. 2.

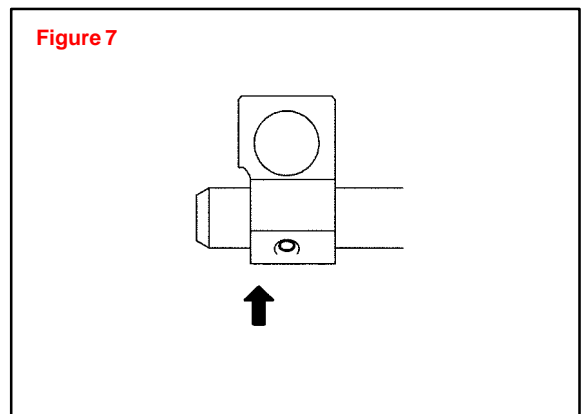

- Remove the transfer RH bearing retainer sub-assembly by removing the 5 bolts.

HINT:
If necessary, tap the extension housing with a plastic hammer to remove it.

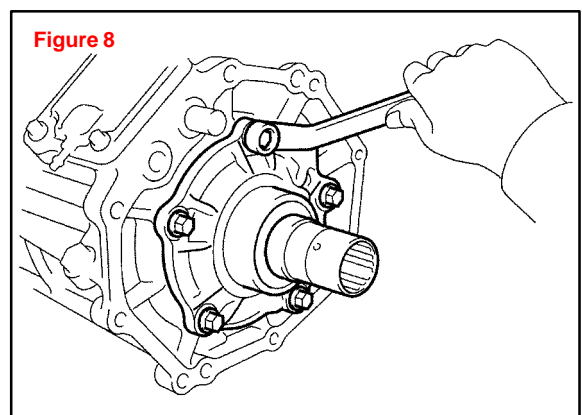

**Repair
Procedure**
(Continued)

9. Remove the transfer cover type T oil seal.
Using a screwdriver and hammer, remove the oil seal from the bearing retainer sub-assembly.

10. Remove the transfer case cover sub-assembly by removing the 4 bolts.

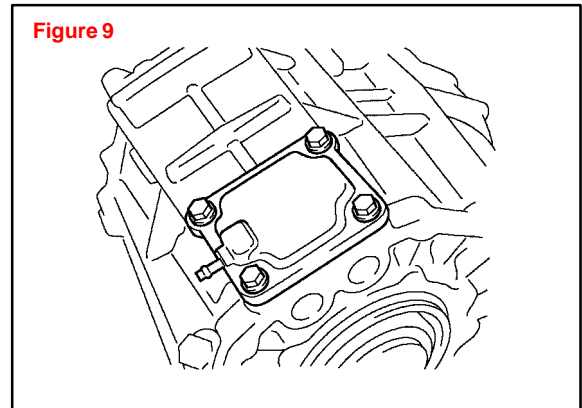

11. Remove the breather oil deflector.

12. Remove the front output shaft companion flange sub-assembly.

- A. Using a chisel and hammer, loosen the staked part of the output shaft companion flange lock nut.
- B. Using the SST to hold the output shaft companion flange, remove the output shaft companion flange lock nut.

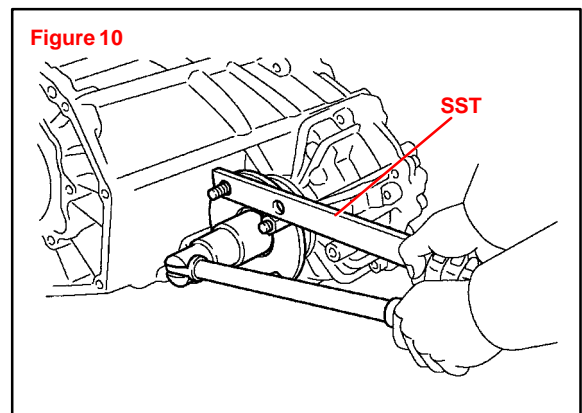

- **SST P/N 09330-00021**

- C. Using the SSTs, remove the front output shaft companion flange sub-assembly.

- **SST P/N 09950-40011-02 (09951-04020, 09952-04010, 09953-04030, 09954-04010, 09955-04051, 09957-04010, 09958-04011)**

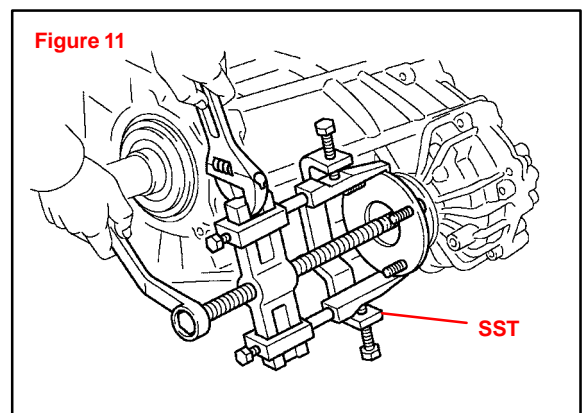

13. Remove the front transfer output shaft companion flange oil seal.

Using a screwdriver and hammer, remove the oil seal from the output shaft companion flange sub-assembly.

14. Remove the rear output shaft companion flange sub-assembly in the same way as the front output shaft companion flange sub-assembly (step 12).

Repair Procedure
(Continued)

15. Remove the rear transfer output shaft companion flange oil seal.
Using a screwdriver and hammer, remove the oil seal from the rear output shaft companion flange sub-assembly.

16. Remove the extension housing assembly by removing the 5 bolts.

HINT:
If necessary, tap the extension housing assembly rear with a plastic hammer to remove it.

17. Remove the transfer extension housing type T oil seal.
Using a screwdriver and hammer, remove the oil seal.

18. Remove the 2 transfer output washers and collar.

19. Remove the transfer case rear by removing the 12 bolts and 2 clamps.

HINT:
If necessary, tap the transfer case rear with a plastic hammer to remove it.

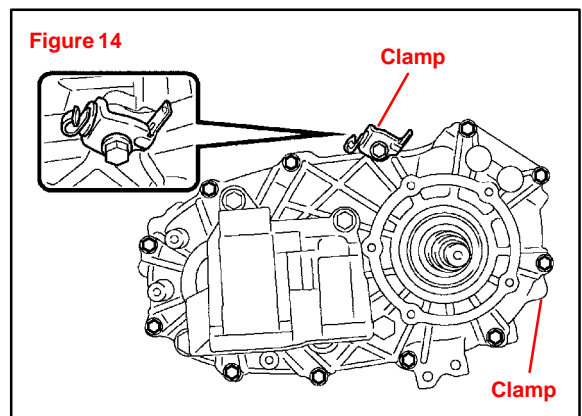
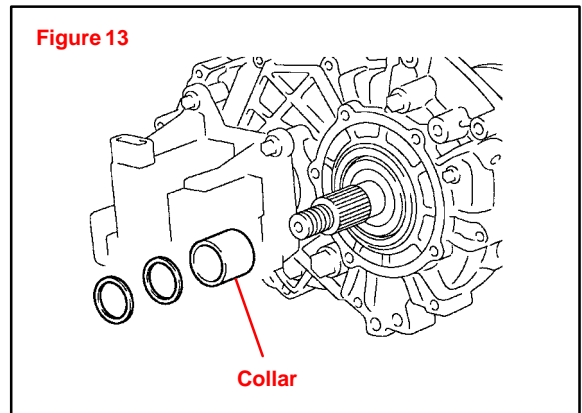
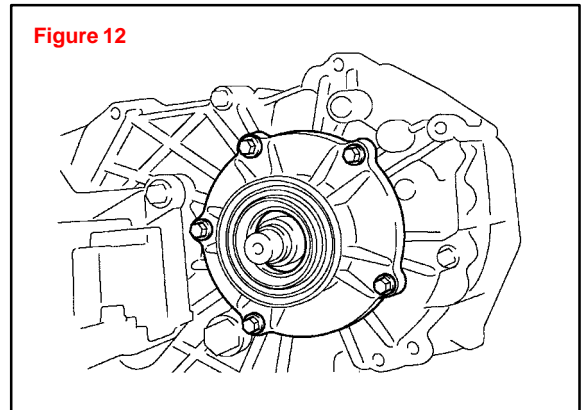

**Repair
Procedure**
(Continued)

20. Remove the transfer gear shift fork No. 2 w/transfer high and low clutch sleeve.
- Using a hexagon wrench, remove the plug No. 1.
 - Using a magnetic finger, remove the spring and ball from the hole.
 - Using a pin punch and hammer, drive out the slotted spring pin.
 - Remove the gear shift fork No. 2 and high and low shift fork shaft.
 - Remove the high and low clutch sleeve.

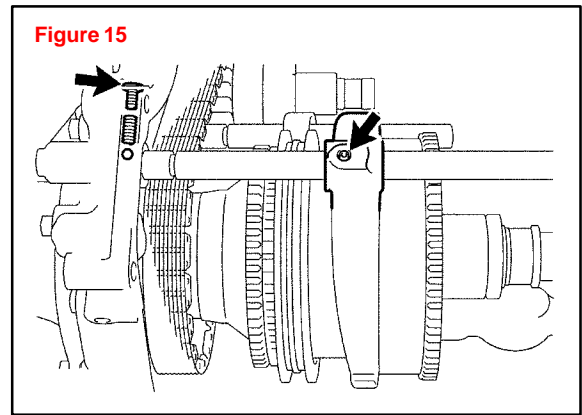

21. Remove the center differential lock fork sub-assembly w/front drive clutch sleeve.
- Using 2 screwdrivers and a hammer, tap out the snap ring.

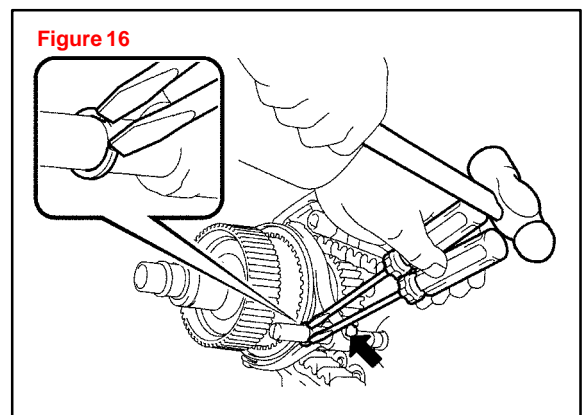

- Remove the bolt, center differential lock fork sub-assembly, and front drive clutch sleeve.

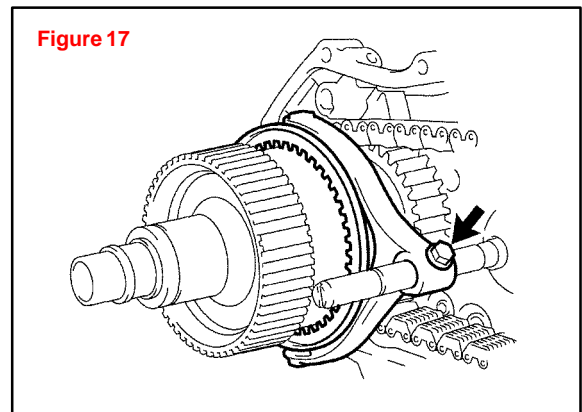

**Repair
Procedure**
(Continued)

22. Remove the rear output shaft sub-assembly, front drive chain, and driven sprocket sub-assembly.

- A. Using a snap ring expander, remove the snap ring.
- B. Mount the transfer case rear in a vise.

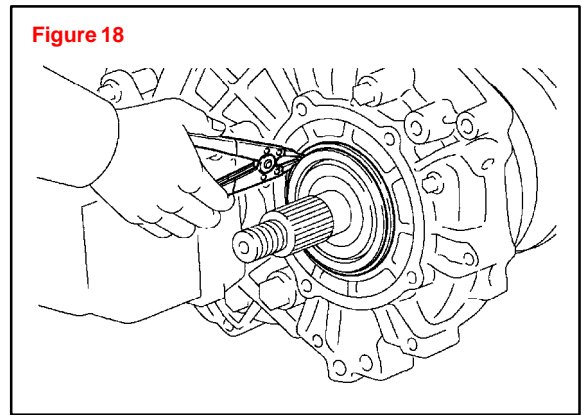

- C. Using a plastic hammer, carefully tap the transfer case rear, and remove the rear output shaft sub-assembly together with the front drive chain and the driven sprocket sub-assembly.

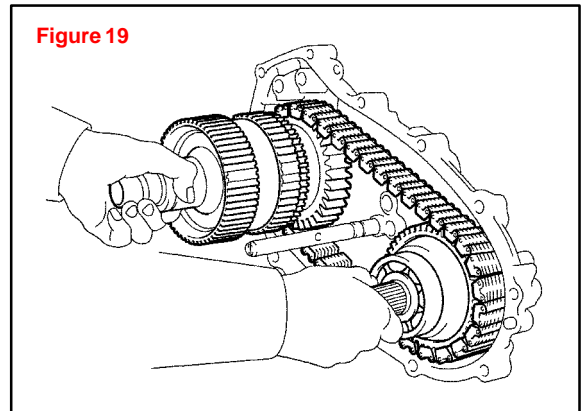

- D. Remove the rear output shaft sub-assembly, front drive chain, and driven sprocket sub-assembly.

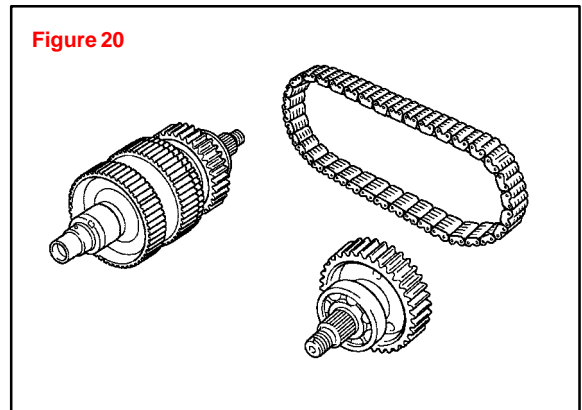

23. Replace the front drive chain with the NEW revised chain assembly.

24. Using a screwdriver and hammer, remove the transfer case oil seal No. 1 and No. 2.

Repair Procedure
(Continued)

25. Install the transfer case oil seal.
- A. Using the SST (or equivalent tool) and a hammer, drive in a NEW oil seal until its surface is flush with the case upper surface (No. 1).
 - **SST P/N 09316-60011 (09316-00011, or equivalent)**
 - B. Coat the lip of the oil seal with MP grease.
 - C. Using the SST (or equivalent tool) and a hammer, drive in a NEW oil seal until its surface is flush with the case upper surface (No. 2).
 - **SST P/N 09304-12012 (or equivalent)**

Oil seal drive in depth:
-0.5 to 0.5 mm (-0.020 to 0.020 in.)
 - D. Coat the lip of the oil seal with MP grease.

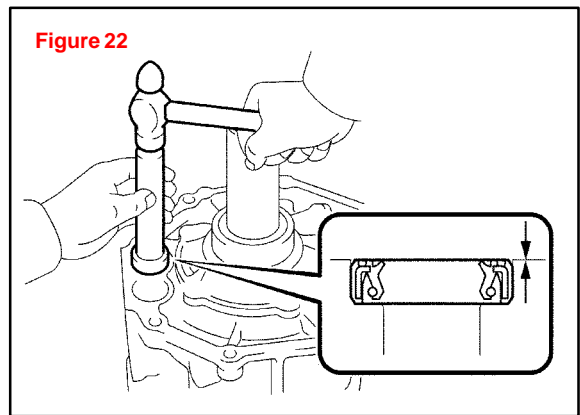
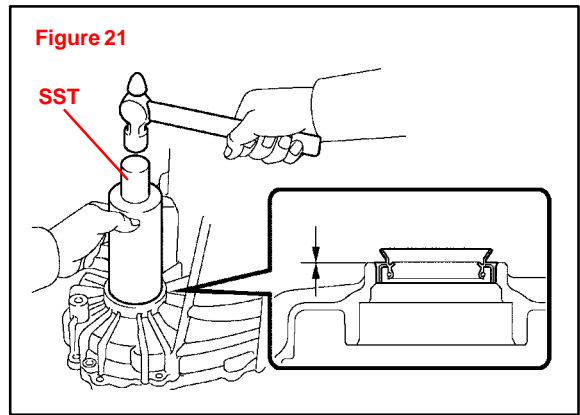

26. Install the rear output shaft sub-assembly, front drive chain, and driven sprocket sub-assembly.
- A. Install the rear output shaft sub-assembly and driven sprocket to the front drive chain.

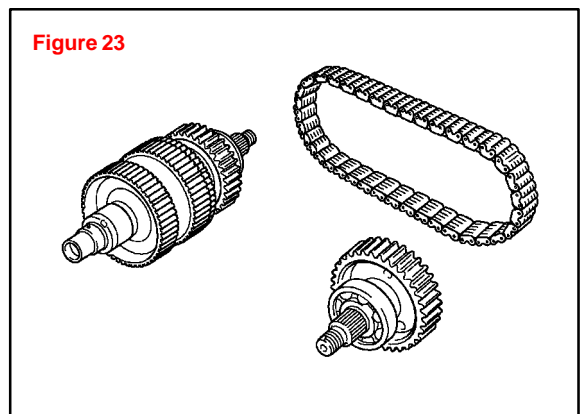

- B. Install the rear output shaft sub-assembly, front drive chain, and driven sprocket sub-assembly to the case rear.

HINT:
Check that the rear output shaft sub-assembly and driven sprocket sub-assembly turn lightly. If necessary, heat the rear case to about 122 – 176°F (50 – 80°C).

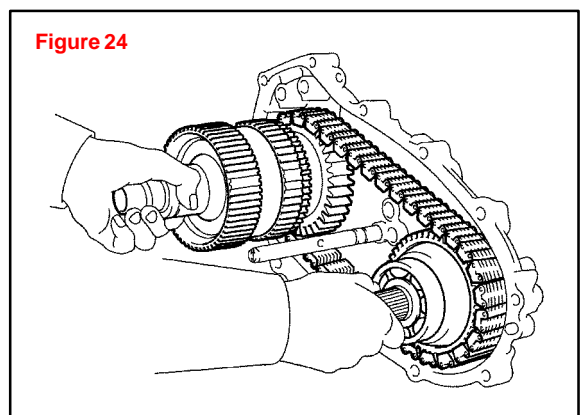

**Repair
Procedure**
(Continued)

- C. Using a snap ring expander,
install the snap ring.

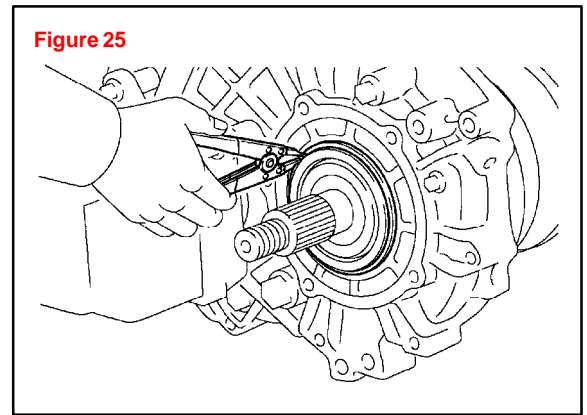

27. Install the center differential lock
fork sub-assembly w/front drive
clutch sleeve.
- A. Install the center differential lock
fork sub-assembly and front drive
clutch sleeve.
- B. Install the bolt.
Torque: 24 N•m
(245 kgf•cm, 18 ft•lbf)

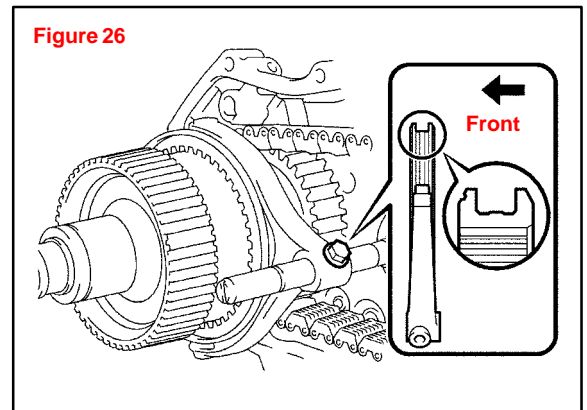

- C. Using a screwdriver and hammer, drive in the snap ring.

NOTE:

Make sure to install the fork and clutch sleeve in the correct direction.

Repair Procedure
(Continued)

28. Install the transfer gear shift fork No. 2 w/transfer high and low clutch sleeve.
 - A. Install the gear shift fork No. 2 and high and low shift fork shaft and high and low clutch sleeve.

NOTE:
Make sure to install the fork in the correct direction.

- B. Apply sealant to the plug No. 1 threads.
 - **Sealant: P/N 08833-00080, Toyota Genuine Adhesive 1344, Three Bond 1344, Loctite 242, or equivalent**
- C. Install the spring and ball to the hole.
- D. Install the plug No. 1 to the hole.

Torque: 18.6 N•m (190 kgf•cm, 14 ft•lbf)
- E. Using a pin punch and hammer, Install the slotted pin.

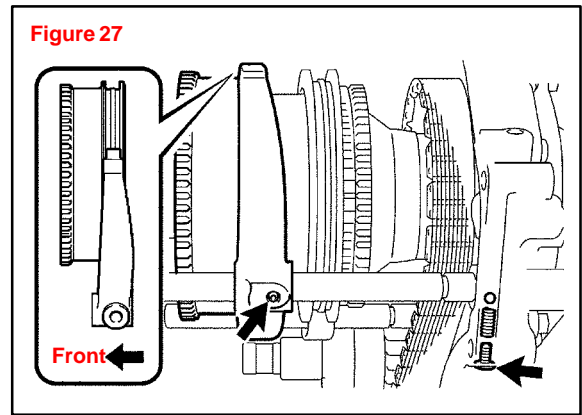

29. Install the transfer rear case.
 - A. Apply FIPG sealant to the transfer rear case, as shown.

- **FIPG sealant: P/N 08826-00090, Three Bond 1281, or equivalent**

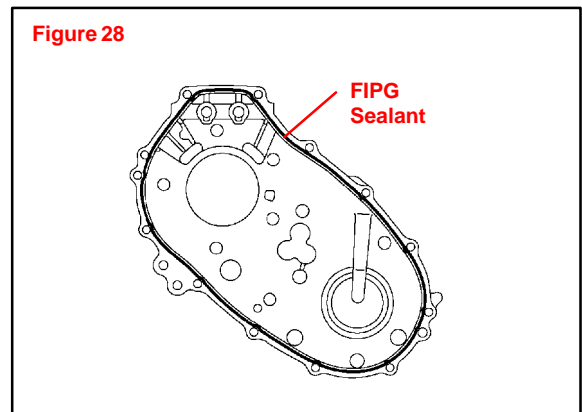

- B. Install the 2 clamps and transfer rear case with the 12 bolts.

Torque: 28 N•m (285 kgf•cm, 21 ft•lbf)

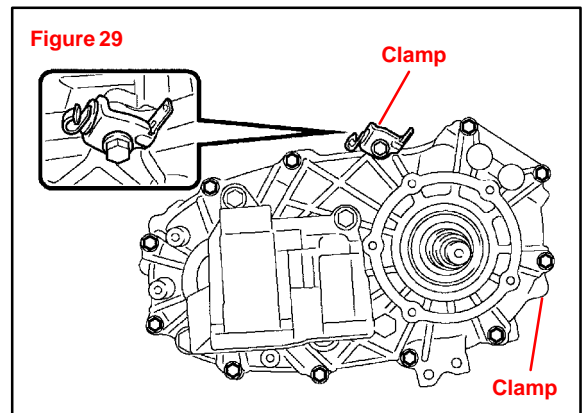

Repair Procedure
(Continued)

30. Install the collar and 2 transfer output washers.

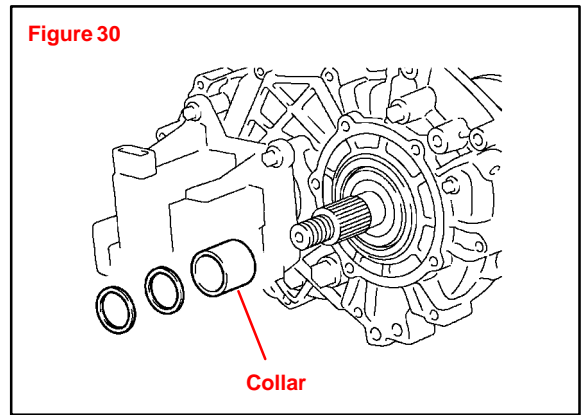

31. Install the transfer extension housing type T oil seal.

- A. Using the SSTs and a hammer, drive in a NEW oil seal until its surface is flush with the housing upper surface.
 - **SST P/N 00002-62091-02 (09223-46011), 09631-32020**
- B. Coat the lip of the oil seal with MP grease.

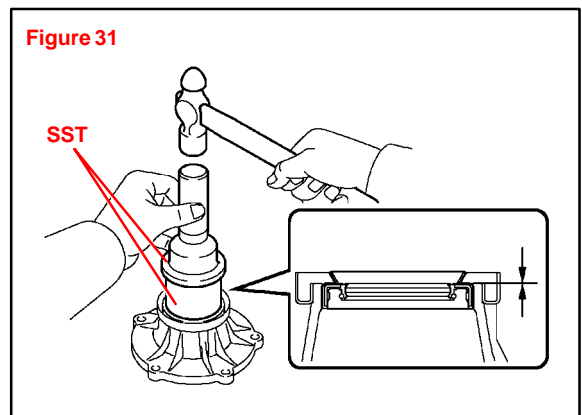

32. Install the extension housing assembly.

- A. Apply FIPG sealant to the extension housing assembly rear, as shown.
 - **FIPG sealant: P/N 08826-00090, Three Bond 1281, or equivalent**
- B. Apply sealant to the bolt threads.
 - **Sealant: P/N 08833-00080, Toyota Genuine Adhesive 1344, Three Bond 1344, Loctite 242, or equivalent**

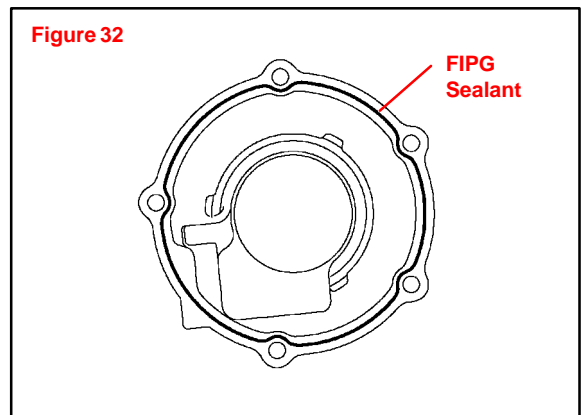

**Repair
Procedure**
(Continued)

- C. Install the extension housing assembly with the 5 bolts.
Torque: 12 N•m (122 kgf•cm, 9 ft•lbf)

Figure 33

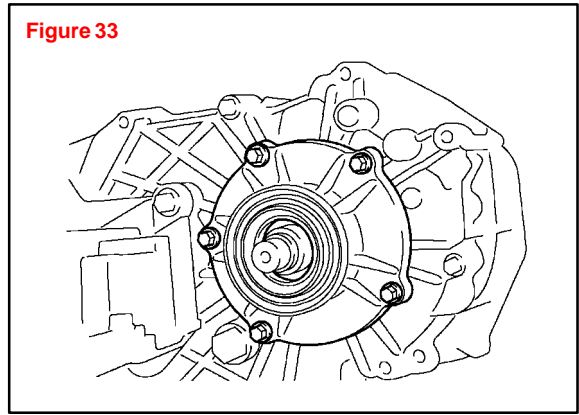

33. Install the front transfer output shaft companion flange oil seal.
- Using the SSTs and a hammer, drive in a NEW oil seal.
 - SST P/N 09950-60010-02 (09951-00320-01), 09950-70010-02 (09951-07100-01)**
 - Coat the lip of the oil seal with MP grease.
34. Install the rear transfer output shaft companion flange oil seal.
- Using the SSTs and a hammer, drive in a NEW oil seal.
 - SST P/N 09950-60010-02 (09951-00320-01), 09950-70010-02 (09951-07100-01)**
 - Coat the lip of the oil seal with MP grease.

Figure 34

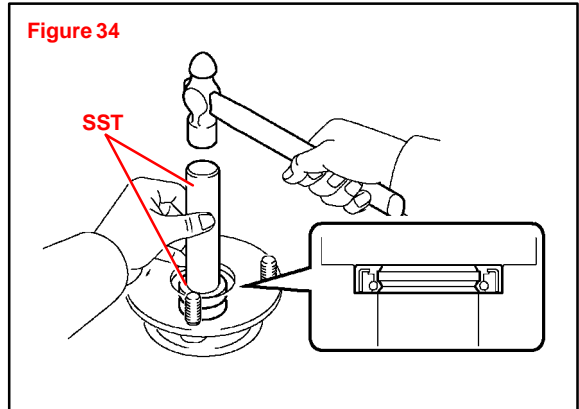

Repair Procedure
(Continued)

35. Install the front output shaft companion flange sub-assembly.
 - A. Install the companion flange sub-assembly to the drive sprocket sub-assembly.
 - B. Using the SST to hold the companion flange, install a NEW companion flange lock nut.
 - **SST P/N 09330-00021**
 - C. Using a chisel and hammer, stake the companion flange lock nut.
36. Install the rear output shaft companion flange sub-assembly.

Using the SST, install the rear companion flange sub-assembly in the same way as the front companion flange sub-assembly.

- **SST P/N 09330-00021**
- Torque: 118 N•m**
(1,203 kgf•cm, 87 ft•lbf)

37. Install the breather oil deflector.
38. Install the transfer case cover sub-assembly with the 4 bolts.

- **Torque: 18 N•m**
(184 kgf•cm, 13 ft•lbf)

39. Install the transfer cover type T oil seal.
 - A. Using the SSTs and a hammer, drive in a NEW oil seal until its surface is flush with the retainer upper surface.
 - **SST P/N 09950-60010-02 (09951-00590-01), 09950-70010-02 (09951-07100-01)**
 - B. Coat the lip of the oil seal with MP grease.

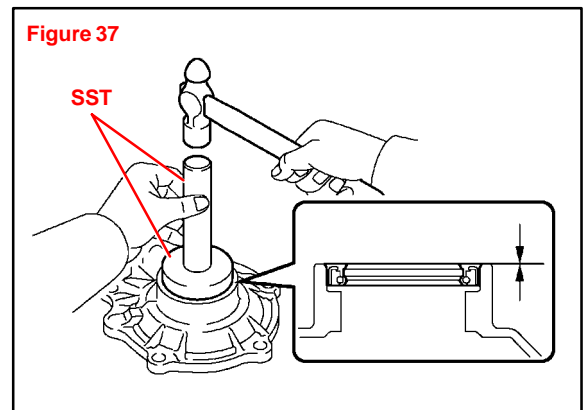
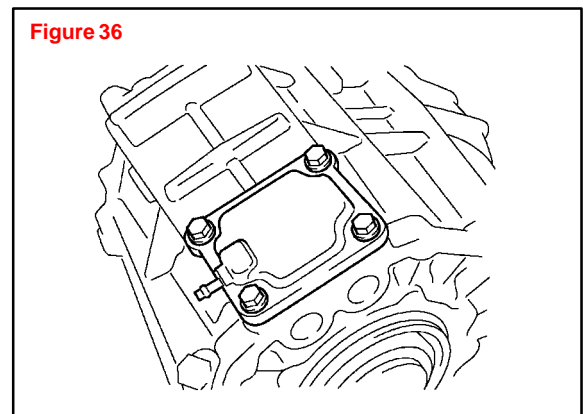
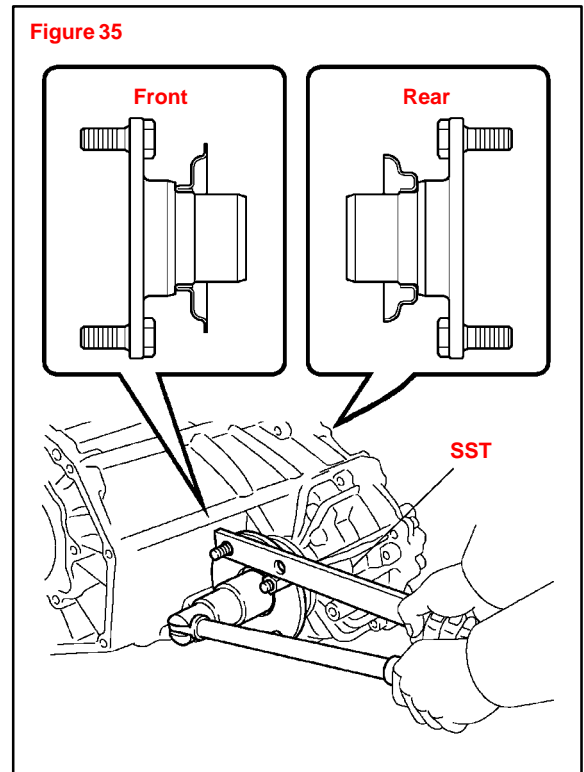

Repair Procedure
(Continued)

40. Install the transfer RH bearing retainer sub-assembly.
 - A. Apply FIPG sealant to the bearing retainer sub-assembly, as shown.
 - **FIPG sealant:**
P/N 08826-00090,
Three Bond 1281,
or equivalent
 - B. Apply sealant to the bolt thread.
 - **Sealant: P/N 08833-00080,**
Toyota Genuine Adhesive 1344, Three Bond 1344,
Loctite 242, or equivalent
 - C. Install the bearing retainer sub-assembly with the 5 bolts.
Torque: 11.5 N•m
(117 kgf•cm, 8 ft•lbf)

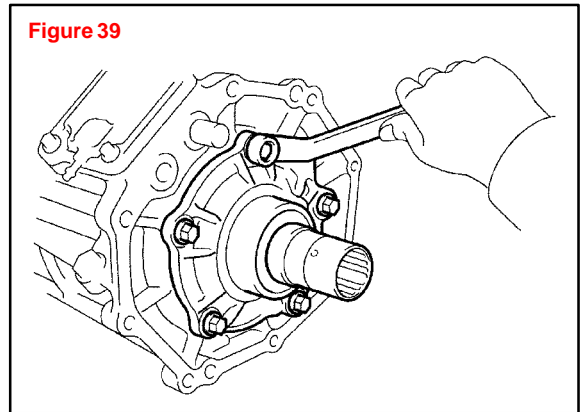
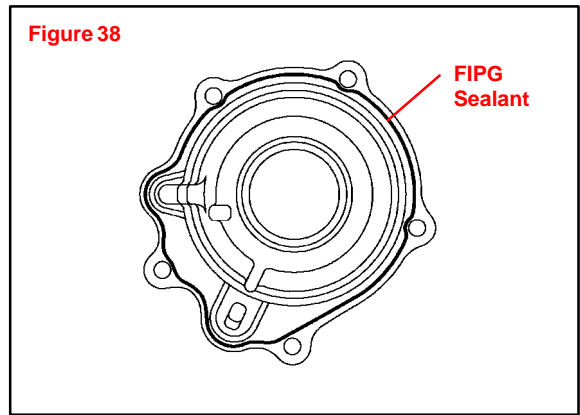

41. Install the transfer gear shift head No. 2.
Using a pin punch and hammer, install the slotted pin to the gear shift head No. 2.

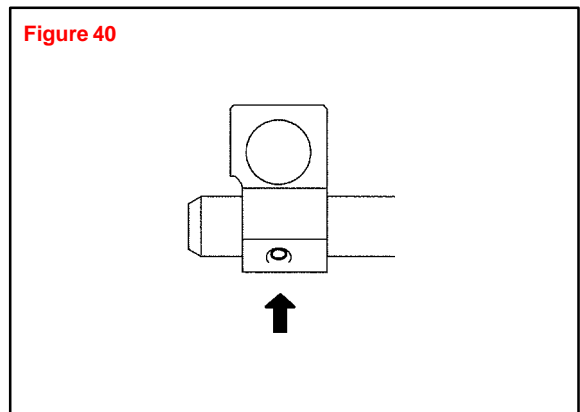

**Repair
Procedure**
(Continued)

42. Install the switches.

Install NEW gaskets, the indicator switches, and the case No. 1 plug.

Torque: 37 N•m (377 kgf•cm, 27 ft•lbf)

Figure 41

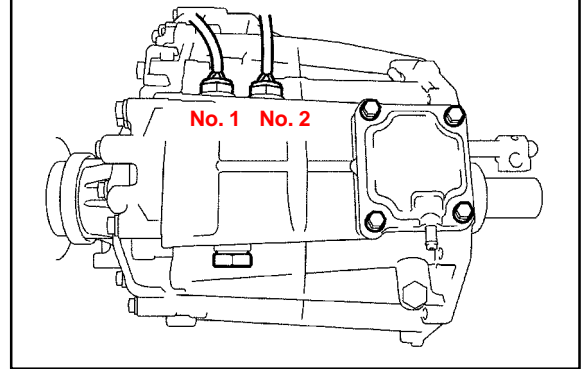

43. Install hoses.

NOTE:

- Place the hose between the transfer rear case and the actuator motor.
- Adjust the clamp position to prevent excessive bending, pulling, or pushing on the hose.

Figure 42

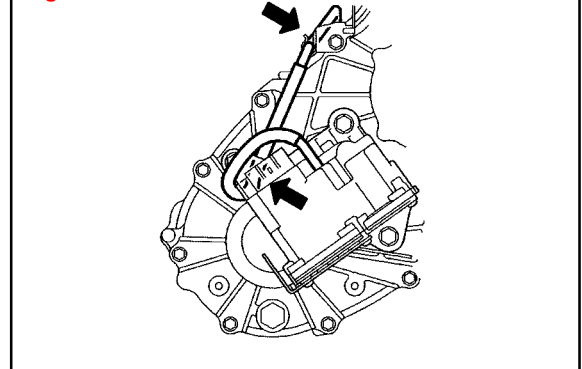

44. Install the transfer assembly.

- Install the transfer to the automatic transmission.
- Install the 2 clamps and 8 bolts.

Torque: 24 N•m (245 kgf•cm, 17 ft•lbf)

45. Install the automatic transmission assembly.

Refer to TIS:

- 2003, 2004, or 2005 model year GX 470 Repair Manual: *Drivetrain – Automatic Transmission/Transaxle – “Automatic Transmission Assy: Replacement”*
- 2006 or 2007 model year GX 470 Repair Manual: *Drivetrain – Automatic Transmission/Transaxle – “A750F Automatic Transmission: Automatic Transmission Assembly: Installation”*

46. Install the transfer case lower protector with the 4 bolts.

Torque: 18 N•m (184 kgf•cm, 13 ft•lbf)

47. Add transfer oil.

Refer to TIS:

- 2003, 2004, or 2005 model year GX 470 Repair Manual: *Drivetrain – Transfer/4wd/Awd – “Transfer Oil: Adjustment”*
- 2006 or 2007 model year GX 470 Repair Manual: *Drivetrain – Transfer/4wd/Awd – “VF4BM Transfer: Transfer Oil: Adjustment”*

**Repair
Procedure**
(Continued)

48. Install the dynamic damper to the transfer case with 2 bolts.

Torque: 38 N-m (387 kgf-cm, 28 ft-lbf)

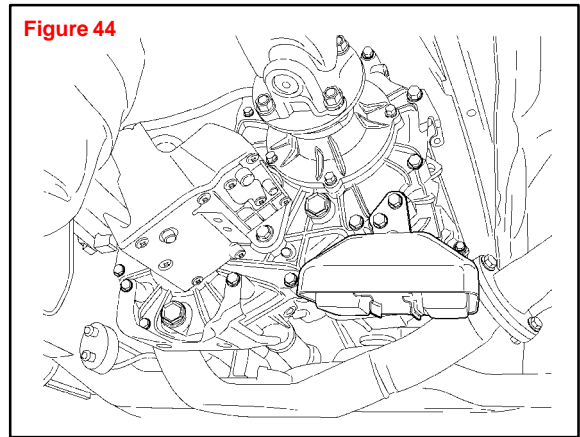
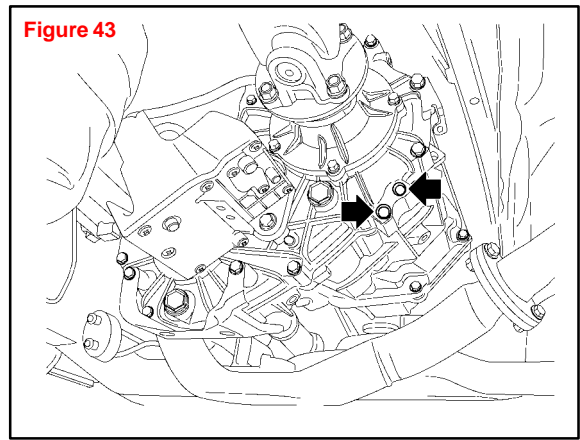

49. Test drive the vehicle to confirm the vibration/drone is eliminated.